

Royal Government of Bhutan
Ministry of Home and Cultural Affairs
Department of Culture
Division of Culture and heritage sites

Pemagatshel Dzong Construction Project



Bidding Document for Supply and Installation of Aluminum Partition Works at Pemagatshel Dzong Construction Project

Bidder;

.....
.....

Full Postal Address;

.....
.....

Phone Number;.....

Email id;

Fax Number;

Dated Sign..... Bidders Name.....

Preface

This Standard Bidding Document for the Procurement of small works up to Nu. 4 million has been prepared by the Public Procurement Policy Division (PPPD) Ministry of Finance to be used for the Procurement of small works through National Competitive Bidding (NCB) in projects that are financed in whole or in part by the Royal Government of Bhutan (RGoB). It should be used in conjunction with the Procurement Rules and Regulations.

Those wishing to submit comments or questions on this Bidding Document or to obtain additional information on procurement under RGoB-financed projects may contact:

Public Procurement Policy Division (PPPD)
Ministry of Finance
Royal Government of Bhutan
pppd@mof.gov.bt

ROYAL GOVERNMENT OF BHUTAN
PEMAGATSHEL DZONG CONSTRUCTION PROJECT
DIVISION FOR CONSERVATION OF HERITAGE SITES
DEPARTMENT OF CULTURE
MINISTRY OF HOME AND CULTURAL AFFAIRS

INVITATIONS FOR BIDS (IFB)

NATIONAL COMPETITIVE BIDDING

Date:

Bid No.:

1. The *Pemagatshel Dzong Construction Project under the Division for Conservation of Heritage Sites, Department of Culture, Ministry of Home and Cultural Affairs* invites bids for the Supply and Installation of Various Items; Aluminium Partition Works
2. Bidding documents (and additional copies) may be purchased from the office of the Accounts Sections, **PDCP, Denchi, Pemagatshel from February 26, 2019 to March 15, 2019 for a non-refundable fee of Nu. 500.00 or can be downloaded from www.departmentofculture.gov.bt** Interested bidders may obtain further information at the office of the Dzong Construction Project, Denchi, Pemagatshel.
3. Bids must be accompanied by a bid security of **Nu. 100,000.00 (Ngultrum One Hundred Thousand only)** drawn in favor of Project Manager, Pemagatshel Dzong Construction Project. Bid security will have to be in any one of the forms as specified in the bidding document and shall have to be valid for 180 days beyond the validity of the bid.
4. Bids must be delivered to the site office of Dzong Construction Project on or before **1:30 PM March 15, 2019 and will be opened on the same day at 02:00 PM** in the conference hall, PDCP in presence of the bidders who wish to attend.

Contents

INVITATIONS FOR BIDS (IFB)	Error! Bookmark not defined.
Section 1: Instructions to Bidder (ITB)	6
A. General	6
1. Scope of Tender.....	6
2. Corrupt Fraudulent Collusive or Coercive Practices	6
3. Eligible Bidders.....	7
4. Site Visit.....	7
B. Content of Bidding Document	7
5. Contents of Bidding Documents	7
6. Clarification of Bidding Documents	8
7. Amendment of Bidding Documents	8
C. Preparation of Bids	8
8. One Bid per Bidder	8
9. Bid Preparation Costs	8
10. Language of Bid	8
11. Documents comprising the Bid	8
13. Alternative Bid	9
14. Bid Price and Discount.....	9
15. Currencies of Bid and Payment.....	9
16. Documents comprising the Technical Proposal.....	9
17. Documents establishing the Qualification of the Bidder	9
18. Bid Validity	9
20. Format and Signing of Bid	10
D. Submission and Opening of Bids	10
21. Sealing and Marking of Bids	10
22. Bid Submission Deadline.....	10
23. Late Bids.....	11
24. Modification, Substitution or Withdrawal of Bids.....	11
25. Bid Opening	11
E. Tender Opening and Evaluation	11
26. Confidentiality	11
27. Clarification	11
28. Bidder: Contacting the Employer.....	11
29. Determination of Responsiveness	12
30. Non Conformities, Errors and Omissions.....	12
31. Evaluation and Comparison of Tenders.....	12
32. Employer's Right to Accept or Reject any or all	13
F. Contract Award	13
33. Award Criteria.....	13
34. Letter of Intent to Award the Contract/ Notification of Award	13
35. Complaints	13
Section 2 - Bidding Data Sheet	14
A. General	14
B. Bidding Documents	14
C. Preparation of Bids	14

D.	Submission and Opening of Bids	15
F.	Award of Contract	15
Section 3 – Evaluation and Qualification Criteria.....		15
Section 4: Forms of Bid & Qualification Information		16
	Standard Form: Form of bid.....	17
	Standard Form: Qualification Information	18
	Standard Form: Letter of Intent.....	19
	Standard Form: Letter of Acceptance	20
	Bank Guarantee for Bid Security	21
Section 5. General Conditions of Contract.....		22
1.	Definitions.....	22
2.	Interpretation & Documents forming the Contract	22
3.	Corrupt, Fraudulent, Collusive or Coercive Practices	23
4.	Governing Language and Law.....	24
5.	Engineer's Decision	24
6.	Delegation	24
7.	Communications and Notices	24
8.	Sub- Contracting	24
9.	Contractor's Personnel.....	24
10.	Welfare of Labourers & Child Labour	24
11.	Safety, Security and Protection of the Environment.....	25
12.	Access to the Site	25
13.	Documents, Information.....	25
14.	Property	25
15.	Insurance.....	25
16.	Possession of the Site.....	25
17.	Commencement of Works	25
18.	Completion of Works	25
19.	Programme of Works	26
20.	Early Warning	26
21.	Compensation Events	26
22.	Non-Scheduled Items of Works.....	26
23.	Schedule of Works.....	26
24.	Payment Certificates	26
25.	Payments and Currency	26
26.	Retention	27
27.	Liquidated Damages.....	27
28.	Performance Security.....	27
29.	Price Adjustment	27
30.	Completion	27
31.	Correction of Defects.....	27
32.	Taking Over	27
33.	Final Account.....	28
34.	Termination	28
35.	Payment upon Termination	29
36.	Release from Performance	29
37.	Force Majeure	29
38.	Settlement of Disputes	30
Section 6. Special Conditions of Contract		34

Section 7 – Contract Forms.....	36
Form-1.....	37
Form-2.....	38
Contract Agreement.....	38
Form-3.....	39
Bank Guarantee for Performance Security.....	39
Bank Guarantee for mobilisation advance.....	40

Section 1: Instructions to Bidder (ITB)

A. General

- | | | | |
|----|--|-----|--|
| 1. | Scope of Tender | 1.1 | The Employer, as indicated in the BDS issues this Bidding Document for the procurement of Works as specified in Section 6 (Employer’s requirement): The name, identification and identification of this bidding are provided in the BDS . |
| | | 1.2 | The successful Bidder will be required to complete the Works within the Time for Completion stated in the Special Conditions of Contract (SCC). |
| | | 1.3 | Throughout this Bidding Documents; <ul style="list-style-type: none"> (a) The term “in writing means communicated in written form with proof of receipt; (b) If the context so requires, singular means plural and vice versa; and (c) “day” means calendar day. |
| 2. | Corrupt Fraudulent Collusive or Coercive Practices | 2.1 | The Royal Government of Bhutan requires that Employers and the Bidders shall observe the highest standard of ethics during the implementation of procurement proceedings and the execution of Contracts under public funds. |
| | | 2.2 | In pursuance of this requirement, the Employer shall <ul style="list-style-type: none"> (a) exclude the bidder from participation in the procurement proceeding concerned or reject a proposal for award; and (b) declare a bidder ineligible, either indefinitely or for a stated period of time, from participation in procurement proceedings under public funds; |
| | | 2.3 | If it, at any time, determines that the bidder has engaged in corrupt, fraudulent, collusive or coercive practices in competing for, or in executing, a Contract under the public funds. |
| | | 2.4 | The Government defines, for the purposes of this provision, the terms set forth below as follows : <ul style="list-style-type: none"> a) “corrupt practice”¹ is the offering, giving, receiving or soliciting, |

¹ ‘Another party’ refers to a public official acting in relation to the procurement process or contract execution.

directly or indirectly, of anything of value to influence improperly the actions of another party;

b) **“fraudulent practice”**² is any intentional act or omission including misrepresentation, that knowingly or recklessly misleads, or attempts to mislead, a party to obtain a financial or other benefits or to avoid an obligation;

c) **“collusive practice”**³ is an arrangement between two or more parties designed to achieve an improper purpose, including to influence improperly the actions of another party;

d) **“coercive practice”**⁴ is impairing or harming or threatening to impair or harm, directly or indirectly, any party or the property of the party to influence improperly the actions of a party.

2.5 The bidder shall be aware of the provisions on fraud and corruption stated in GCC Clause 3 and GCC Sub-Clause 34.2(d).

2.6 The RGoB requires that the Employer’s personnel have an equal obligation not to solicit, ask for and/or use coercive methods to obtain personal benefits in connection with the said proceedings.

3. Eligible Bidders 3.1 Bidders of the categories **specified in the BDS** are eligible to participate in this bidding process.

3.2 The Employer shall invite Bids using the Open Tendering Method (National Competitive Bidding) or limited tender as applicable.

3.3 The bidder shall meet the qualification requirement stated in the BDS

4. Site Visit 4.1 The Bidders, at their own responsibility and risk, is encouraged to visit and examine the Site and obtain all information that may be necessary for preparing the bid and entering into a Contract for performance of the Works. The costs of visiting the Site shall be at the bidder’s own expense.

B. Content of Bidding Document

5. Contents of Bidding Documents 5.1 The sections comprising the Bidding Document are listed below and should be read in conjunction with any Amendment issued in accordance with ITB Clause 7:

PART 1 Bidding Procedures

- Section 1: Instructions to Bidders (ITB)
- Section 2: Bidding Data Sheet (BDS)
- Section 3: Evaluation and Qualification Criteria
- Section 4: Bidding forms
- Section 5: General Conditions of Contract (GCC)
- Section 6: Special Conditions of Contract (SCC)
- Section 7: Contract Forms
- Section 8: Bill of Quantities & Specifications
- Section 9: Drawings

² A ‘party’ refers to a public official; the term ‘benefit’ and ‘obligation’ relate to the procurement process or contract execution; and the ‘act or omission’ is intended to influence the procurement process or contract execution.

³ ‘parties’ refers to participations in the procurement process including public officials attempting to establish bid prices at artificial, non competitive levels.

⁴ A ‘party’ refers to a participant in the procurement in the procurement process or contract execution.

5.2 The Employer is not responsible for the completeness of the Bidding Document and their Addenda, if they were not obtained directly from the source stated by the Employer in the Invitation for Bids.

5.3 The Bidder is expected to examine all instructions, forms terms, and specifications in the Bidding Documents. Failure to furnish all information or documentation required by the Bidding Documents may result in the rejection of the bid.

6. Clarification of Bidding Documents 6.1 A prospective Bidder requiring any clarification of the Bidding Document shall contact the Employer in writing at the Employer's address **indicated in the BDS.**

7. Amendment of Bidding Documents 7.1 At any time prior to the deadline for submission of Bid, the Employer may amend the Bidding Document by issuing addenda and extend the deadline for the submission of bids at its discretion. Any amendment issued shall become an integral part of the Bidding Document and shall be communicated in writing to all those who have purchased the Bidding Document.

C. Preparation of Bids

8. One Bid per Bidder 8.1 A Bidder shall submit only one (1) Bid. A Bidder who submits or participates in more than one (1) Bid shall cause all the proposals with the Bidder's participation to be disqualified.

9. Bid Preparation Costs 9.1 The Bidder shall bear all costs associated with the preparation and submission of its Bids, and the Employer shall in no case be responsible or liable for those costs, regardless of the conduct or outcome of the Bidding process.

10. Language of Bid 10.1 All documents relating to the Bid shall be in the language specified in the BDS.

11. Documents comprising the Bid 11.1 The original and copy(ies) of Bid submitted by the Bidder shall comprise the following:

- (a) The Bid form (in the format indicated in Section IV – Forms of Bid, Qualification Information, Letter of Acceptance, and Contract);
- (b) License and certificate
- (c) Bid Security in accordance with Clause 19;
- (d) Priced Bill of Quantities;
- (e) and any other materials required to be completed and submitted by Bidders, as specified in the BDS.

11.2 The Instruction to Bidders, Bidding Data Sheet, General Conditions of Contract, Special Conditions of Contract, Specifications and drawings are for the information of the bidders and is not required to be submitted by the bidder,

12 Letter of Bid and Schedule	12.1	The letter of Bid, Schedules, and all documents listed under Clause 11, shall be prepared using the relevant forms in Section 4 (Bidding Forms), if so provided in BDS. The forms must be completed without any alterations to the text, and no substitutes shall be accepted. All blank spaces shall be filled in with the information requested.
13. Alternative Bid	13.1	Alternative Bid shall not be considered in small works.
14. Bid Price and Discount	14.1	The prices and discounts quoted by the Bidder in the Letter of Bid and in the Schedules shall confirm to the requirements specified below;
	14.2	The bidder shall submit a bid for the whole of the works described in ITB 1.1 by filling in prices for all items of the Works, as identified in Section 4, Bidding Forms. In case of admeasurements contracts, the Bidder shall fill in rates and prices for all items of the Works described in the Bill of Quantities. Items against which no rate or price is entered by the Bidder will not be paid for by the Employer when executed and shall be deemed covered by the rates for other items and prices in the Bill of Quantities.
	14.3	The Bid price shall take into account the cost of materials, transportation, labour, taxes, levies, overheads and profit and any other cost. The Bid price shall be fixed for the duration of performance of the Contract and shall not be subject to any adjustment on any account. The Bid price shall be applicable for the whole works described in the Drawings, Specifications and Schedule of Works.
15 Currencies of Bid and Payment	15.1	All prices shall be quoted in Bhutanese Ngultrum (BTN) and shall be paid in BTN.
16 Documents comprising the Technical Proposal	16.1	The bidder shall furnish a work plan in simple bar chart and other information if provided in BDS, to demonstrate the adequacy of the Bidders' proposal to meet the work requirements and the completion time.
17 Documents establishing the Qualification of the Bidder	17.1	To establish its qualification to perform the Contract in accordance with Section 3 (Evaluation and Qualification Criteria) the Bidder shall provide the information requested in the corresponding information sheets included in Section 4 (Bidding Forms)
18 Bid Validity	18.1	Bids shall remain valid for the period specified in the BDS . Any Bids which does not meet the validity requirement as per the BDS shall be rejected by the Employer as non-responsive.
19 Bid Security	19.1	The Bidder shall at their option furnish, as part of the Bid, a Bid Security as specified in the BDS issued by any reputed Financial Institutions in Bhutan and shall be valid thirty (30) days beyond the Bid validity period. <ul style="list-style-type: none"> a) Unconditional Bank Guarantee; b) A demand Draft; or c) Cash Warrant
	19.2	In exceptional circumstances, prior to the expiration of the Bid validity period, the Employer may solicit the Bidder's consent to an extension of the Bid validity period. The request and responses shall be made in

writing. The validity of Bid Security shall be suitably extended promptly.

- 19.3 The Bid Security may be forfeited:
 - (a) if the Bidder withdraws the Bid after Bid opening during the period of Bid validity. Further the bidder may be excluded from future participation for a period of two years.
 - (b) if the Bidder does not accept the correction of the Bid price, pursuant to clause 31; or
 - (c) in the case of a successful Bidder, if the Bidder fails within the specified time limit to sign the Agreement; or furnish the required Performance Security.
- 20 Format and Signing of Bid
 - 20.1 The Bidder shall prepare one (1) original of the documents comprising the Bid as described in ITB Clause 11 and clearly mark it "ORIGINAL." In addition, the Bidder shall prepare the number of copies of the Bid, as specified in the BDS and clearly mark each of them "COPY." In the event of any discrepancy between the original and the copies, the original shall prevail.
 - 20.2 The original and each copy of the Bid shall be typed or written in indelible ink and shall be signed by the person duly authorized to sign on behalf of the Bidder.
 - 20.3 Any interlineations, erasures, or overwriting shall be valid only if they are signed or initialled by the person(s) signing the Bid.

D. Submission and Opening of Bids

- 21 Sealing and Marking of Bids
 - 21.1 The Bidder shall enclose the original in one (1) envelope and all the copies of the bid in another envelope, duly marking the envelopes as "ORIGINAL" and "COPY." These two (2) envelopes shall then be enclosed in one (1) single outer envelope.
 - 21.2 The inner envelopes shall:
 - (a) Be signed across the seals by the person authorised to sign the Bid on behalf of the Bidder;
 - (b) Be marked "ORIGINAL" and "COPY" and
 - (c) Bear the name and address of the Bidder.
 - 21.3 The outer envelope shall;
 - (a) Be sealed with adhesive or other sealant to prevent reopening;
 - 21.4 be addressed to the Employer at the address specified in the BDS; bear a statement "DO NOT OPEN BEFORE....." the time and date for Bid opening as specified in the BDS.
 - 21.5 If all or any envelopes are not sealed and marked as required by ITB Sub-Clause 21, the Employer **shall not reject the bids but assume no responsibility for the misplacement or premature opening of the Bid.**
- 22 Bid Submission Deadline
 - 22.1 Bids must be received by the Employer at the address and no later than the date and time **specified in the BDS.**
 - 22.2 Bids may be hand delivered, posted by registered mail or sent by courier.
 - 22.2 The Employer may, at its discretion, extend the deadline for the submission of Bids by amending the Bidding Document in accordance with ITB Clause 7, in which case all rights and obligations of the Employer

and Bidders previously subject to the deadline shall thereafter be subject to the new deadline as extended.

- 23 Late Bids 23.1 Late bids shall not be considered and shall be returned unopened

- 24 Modification, Substitution or Withdrawal of Bids 24.1 A Bidder may modify, substitute or withdraw their Bids after it has been submitted by sending a written notice before the deadline for submission of Bids.

- 25 Bid Opening 25.1 The Employer shall open the Bids in the presence of the bidders who is attending the bid opening, including modifications or substitutions made pursuant to ITB Clause 24. Bidders or their representatives shall be allowed to attend and witness the bid opening and shall sign a register evidencing their attendance.
25.2 The name of the Bidder, Bid modifications, substitutions or withdrawals, total amount of each Bid, number of corrections, discounts, and the presence or absence of requisite Bid Security, and such other details as the Employer, at its discretion, may consider appropriate, shall be read out aloud and recorded.
25.3 The Employer shall prepare minutes of the Bid opening. The minutes shall include, as a minimum, the name of the Bidders and whether there has been a withdrawal, substitution or modification; the Bid Price including any discounts and the presence or absence of a Bid Security, if one was required.
25.4 Bids not opened and read out at the Bid opening shall not be considered, irrespective of the circumstances, and shall be returned unopened to the Bidder.

E. Tender Opening and Evaluation

- 26 Confidentiality 26.1 After the opening of Bids, information relating to the examination, clarification, and evaluation of Bids and recommendations for award shall not be disclosed to Bidders or other persons not officially concerned with the evaluation process until after the award of the Contract is announced.

- 27 Clarification 27.1 The Employer may ask Bidders for clarification of their Bids in order to facilitate the examination and evaluation of Bids. The request for clarification and the response shall be in writing, and any changes in the prices or substance of the Bid shall not be sought, offered or permitted, except to confirm the correction of arithmetical errors discovered by the Employer in the evaluation of the Bids, in accordance with ITB Clause 31.

- 28 Bidder: Contacting the Employer 28.1 Following the opening of Bids and until the Contract is signed no Bidder shall make any unsolicited communication to the Employer or try in any way to influence the Employer's examination and evaluation of Bids which may result in the rejection of bids. If any Bidder wishes to contact the Employer on any matter related to the Bidding process, it should do so in writing

- 29 Determination of Responsiveness
- 29.1 Prior to detailed evaluation of bids, the employer shall determine whether each bid (a) meets the eligibility criteria defined in ITB clause 3; (b) has been properly signed; (c) is accompanied by the bid security; and (d) is substantially responsive to the requirements of the bidding documents.
- 29.2 A substantially responsive Bid is one that conforms in all respects to the requirements of the Bidding Document without material deviation, reservation or omission. A material deviation, reservation or omission is one that:
- (a) affects in any substantial way the scope, quality, or performance of the Works specified in the Contract; or
 - (b) limits in any substantial way, or is inconsistent with the Bid Document, the Employer's rights or the Bidder's obligations under the Contract; or
 - (c) if rectified would unfairly affect the competitive position of other Bidders presenting substantially responsive Bids.
- 29.3 If a Bid is not substantially responsive to the Bidding Document it shall be rejected by the Employer and shall not subsequently be made responsive by the Bidder by correction of the material deviation, reservation or omission.
- 29.4 There shall be no requirement as to the minimum number of responsive Bids.
- 30 Non Conformities, Errors and Omissions
- 30.1 The Employer may regard a Bid as responsive even if it contains minor deviations that do not materially alter or depart from the characteristics, terms, conditions and other requirement set forth in the Bidding Document or if it contains errors or oversights that are capable of being corrected without affecting the substance of the Bid.
- 31 Evaluation and Comparison of Tenders
- 31.1 The Employer shall evaluate and compare only those Bids determined to be substantially responsive to the requirements of the Bidding Document. Substantially responsive Bids are those which fulfil the requirements of ITB Clauses 11 and 12.
- 31.2 The evaluation will take into account corrected Bid Price and discounts (if any).
- 31.3 The Employer will check substantially responsive Bids for any arithmetical errors. Where there is a discrepancy between the amounts in figures and words, the amount in words will govern. If a Bidder refuses to accept the correction, its Bids shall be rejected. The Employer shall correct arithmetical errors on the following basis:
- (a) if there is a discrepancy between the unit price and the line item total, the unit price shall prevail and the total price shall be corrected, unless in the opinion of the Employer there is an obvious misplacement of the decimal point in the unit price, in which case the total price, as quoted, shall govern and the unit price shall be corrected; and

32. Employer's Right to Accept or Reject any or all 32.1 The Employer reserves the right to accept any Bid, to annul the Bid proceedings, or to reject any or all Bids, at any time prior to Contract award, without thereby incurring any liability to Bidders, or any obligation to inform Bidders of the grounds for the Employer's actions.

F. Contract Award

33. Award Criteria 33.1 The Employer shall award the Contract to the Bidders whose offer is substantially responsive to the Bidding Document and that has been determined to be the lowest evaluated Bid, provided that the Bidder is determined to be qualified to perform the Contract satisfactorily

34. Letter of Intent to Award the Contract/ Notification of Award 34.1 The Employer shall notify the concerned Bidder whose bid has been selected in accordance with ITB 33.1 in writing (in the format in Section 4-hereafter called the "Letter of Intent to Award) that the Employer has intention to accept its bid and the information regarding the name, address and amount of selected bidder shall be given to all other bidders who submitted the bid. Such notification should be communicated in writing, including by cable, facsimile, telex or electronic mail to all the bidders on the same day of dispatch. The Employer shall ensure that the same information is uploaded on their website on the same day of dispatch.

34.2 If no bidder submits an application pursuant to ITB 35 within a period of ten (10) days of the notice provided under ITB 34.1, Prior to the expiration of the period of Bid validity, the Employer shall notify the successful Bidder, in writing that its Bid has been accepted. Until a formal contract is prepared and executed, the Notification of Award shall constitute a binding Contract.

34.3 Within fifteen (15) working days of the receipt of the Notification of Award from the Employer, the successful Bidder shall furnish the Performance Security, in the amount specified in the BDS.

34.4 The proceeds of the performance security shall be payable to the Employer unconditionally upon first written demand as compensation for any loss resulting from the Contractor's failure to complete its obligations under the Contract

34.5 Within fifteen (15) working days of receipt of the notification of award, the successful Bidder shall sign, date and return it to the Employer.

35.Complaints 35.1 The Bidder shall submit the complaint in writing within ten (10) days from the date of letter of intent to award the contract pursuant to ITB 34.1 to the Employer.

35.2 The Bidder may appeal to the Independent Review Body only if the Employer has not delivered the decision within the specified time, or the complainant is not satisfied with the decision of the Employer in accordance with rules and procedures of Independent Review Body.

Section 2 - Bidding Data Sheet	
<i>Instructions for completing the Bidding Data Sheet are provided, as needed, in the notes in italics mentioned for the relevant ITB Clauses</i>	
ITB Clause	Amendment of, and Supplements to, Clauses in the Instructions to Bidders
A. General	
ITB 1.1	The Employer is; Pemagatshel Dzong Construction Project
	The Name and Identification of the Contract is/are; Supply and installation of aluminium Partition works at Pemagatshel Dzong Construction Project. The Works are; <i>supply of materials for aluminium partition with accessories including 5mm double glazing clear glass with ozone fittings, door frame and shutter with hafele fittings complete to project site. Installation of Aluminum partition as per the drawings provided and in close consultation with Project Engineer.</i> ***The designated area for the installation for aluminium partition are at Ground Floor, first floor and second floor of Administrative Blocks C & E.
ITB 3.2	Option B: Open Tendering method All Medium class contractor registered with W3 - Buildings, Irrigation, Drainage, Flood Control, Water Supply and Sewerage with CDB will be participating in the tender.
ITB 3.3	The evaluation shall be based on the lowest evaluated price of the responsive bidder and the work will awarded to the lowest responsive bidder.
B. Bidding Documents	
ITB 7.1	For <u>clarification of Tenders purposes</u> only, the Employer's address is: Attention: Lhaten Dorji, Project Manager Address: Denchi, Pemagatshel Dzongkhag, Bhutan Mobile Number: +97517697328 , Phone Number; +975-07-471341 Facsimile number; +975-07-471341 Electronic mail address: lhatendorji@hotmail.com
C. Preparation of Bids	
ITB 15.1	The Bid validity period shall be [180] days.
ITB 15.2	A Bid Security in the amount of Nu. 100,000.00 (one hundred thousand) only will be required, in the form; a) Cash warrant; or b) Demand draft
ITB 16.1	

ITB 19.1	In addition to the original, [one] copies shall be submitted.
D. Submission and Opening of Bids	
ITB 17.2	The inner and outer envelopes shall bear the following additional identification marks:
ITB 17.2	<p>For Bid submission purposes only, the Employer's address is: Attention: Project Manager, Address: Pemagatshel Dzong Construction Project. The deadline for the submission of Tenders is: 15th March 2019 Time & Date; 1:30PM, 15th March 2019</p>
ITB 21.1	<p>The Bid opening shall take place on the same day as the closing day of the bid submission at: conference room of Pemagatshel Dzong Construction Project Date: [15th March 2019]; Time:[2:00 pm]</p>
F. Award of Contract	
ITB 34.2	The amount of Performance Security shall be [10%] percent of the Contract Price as estimated by the Project Engineer.
ITB 34.1	<p>The Performance Security shall be provided in any one of the following forms:</p> <p>(a) Banker's certified cheque/cash warrant, or (b) Demand draft.</p> <p>In addition to performance security, the successful bidder shall deposit the additional differential security if any, in the form of "Cash Warrant" and should valid for at least 6 months, and thereafter, can be converted in to Bank Guarantee. However, the guarantee should valid up to remaining contract duration.</p> <p>For procurement of all works, the differential security shall be liable if the bid price quoted by the bidders are less than the departmentally estimated cost by over 20% of the departmentally estimated cost. If: departmental estimate=X Quoted bid price=Y Then, the amount to be deposited in Cash Warrant=X-Y-20% of X</p>

Section 3 – Evaluation and Qualification Criteria

This section contains all the criteria that the Employer shall use to evaluate bids and qualify Bidders if the bidding was not preceded by a prequalification exercise and post qualifications are applied. Procuring Agency may

apply basic minimum technical qualification requirement (manpower and equipment) only if there is a project specific need.

1. Evaluation

1.1 Evaluation shall be done to determine the responsiveness and the award shall be made to the lowest evaluated bidder.

Section 4: Forms of Bid & Qualification Information

Table of Standard Forms

Standard Form: Form of Bid
Standard Form: Letter of Intent
Standard Form: Letter of Acceptance
Standard Form: Bid security Bank Guarantee

Standard Form: Form of bid

Notes on Form of Bid:

The Bidder shall fill in and submit this bid form with the Bid. If Bidders do not fill in the Contract Price and does not sign this Bid form, the bids will be rejected..

15th March 2019

**To,
The Project Manager
Pemagatshel Dzong Construction Project
Denchhi, Pemagatshel**

We offer to execute the contract for construction of **“Supply and installation of Aluminum Partition works at Pemagatshel Dzong Construction Project at project site.”** in accordance with the Conditions of Contract accompanying this Bid for the Contract Price of _____ [amount in figures] (_____)
[amount in words] _____ [name of currency].

The contract shall be paid in Ngultrums (Nu.)

This Bid and your written acceptance of it shall constitute a binding Contract between us. We understand that you are not bound to accept the lowest or any Bid you receive.

We hereby confirm that this Bid complies with the Bid validity and Bid Security required by the bidding documents and specified in the Bidding Data.

Authorized

Signature:

(Affix Legal Stamp)

Name and Title of Signatory: _____

Name of Bidder: _____

Address: _____

Dated Sign.....Bidders Name.....

Standard Form: Qualification Information

Notes on Form of Qualification Information: The following information is to be filled in by bidders which will be used for purposes of evaluation

1. Individual bidders

1.1 Constitution of legal status of Bidder [attach copy]

Place of registration: _____

Principal place of business: _____

Power of attorney of signatory of Bid [attach]

1.2 Qualifications and experience of key personnel proposed for administration and execution of the Contract. Refer BDS. The supporting documents such detailed CVs signed in original supported by certificates for qualification and experience.

Position	Name	Qualification & year of experience (general)	Year of experience in proposed position	Remarks

Standard Form: Letter of Intent

(Letterhead paper of the Employer)

Notes on standard form of letter of Intent

This issuance of Letter of Intent (always before letter of acceptance) is the information of the selection of the bid of the successful bidder by the Employer and for providing information to other unsuccessful bidders who participated in the bid as regards the outcome of the procurement process

The Employer shall allow 10 days as described in ITB 34.2 between this letter of intent and letter of acceptance to allow aggrieved bidders to challenge your decision if they feel they have treated unfairly.

(Insert date)

To:-----[Name and address of the Contractor]

This is to notify you that, it is our intention to award the contract for your Bid dated-----
---[Insert date] for execution of the-----
-----[Insert name of the contract and identification number, as given in the BDS/SCC] for the Contract Price of-----
-----[Insert amount in figure and words and name of currency] as corrected and modified [if any corrections] in accordance with the Instructions to Bidders.

Authorized Signature: -----

Name and Title of Signatory:-----

Name of Agency:-----

CC:
[Insert name and address of all other bidders who submitted the bid]

Standard Form: Letter of Acceptance

[letter head paper of the Employer]

Notes on Standard Form of Letter of Acceptance

The Letter of Acceptance will be the basis for formation of the Contract as described in Clauses 31 and 32 of the Instructions to Bidders. This Standard Form of Letter of Acceptance should be filled in and sent to the successful Bidder only after evaluation of bids has been completed.

_____ [date]

To:

[name of the Contractor]

[address of the Contractor]

This is to notify that your Bid dated _____ for the execution of the contract for the construction of “_____” for the Contract Price _____ [amount in numbers] _____ [amount in words] _____ [name of currency], as corrected and modified in accordance with the Instructions to Bidders is hereby accepted by our Agency. The start date of the project is _____. The completion date for whole of the works shall be _____.

You are hereby instructed to proceed with the execution of the said Works in accordance with the Contract documents.

Authorized Signature: _____

Name and Title of Signatory _____

Name of Agency: _____

Attachment: Agreement

Bank Guarantee for Bid Security

[this is the format for the Bid Security to be issued by a financial institutions in Bhutan in accordance with ITB Clause 19]

Invitation for Bid No:

Date:

Bid Package No:

To:

[Name and address of Employer]

TENDER GUARANTEE No:

We have been informed that *[name of Bidder]* (hereinafter called "the Bidder") intends to submit to you its Bid dated *[date of bid]* (hereinafter called "the Tender") for the execution of the Works of *[description of works]* under the above Invitation for Bids (hereinafter called "the IFB").

Furthermore, we understand that, according to your conditions Bids must be supported by a Bid Guarantee.

At the request of the Bidder, we *[name of bank]* hereby irrevocably undertake to pay you, without cavil or argument, any sum or sums not exceeding in total an amount of Nu *[insert amount in figures and words]* upon receipt by us of your first written demand accompanied by a written statement that the Bidder is in breach of its obligation(s) under the Bid conditions, because the Bidder:

- (a) has withdrawn its Bids during the period of Bid validity specified by the Bidder in the Form of Bid; or
- (b) does not accept the correction of errors in accordance with the Instructions to Bidders ITB; or
- (c) having been notified of the acceptance of the Bid by the Employer during the period of Bid validity, (i) fails or refuses to furnish the performance security in accordance with the ITT, or (ii) fails or refuses to execute the Contract Form,

This guarantee will expire

- (a) if the Bidder is the successful Bidder, upon our receipt of a copy of the Performance Security and a copy of the Contract signed by the Bidder as issued by you; or
- (b) if the Bidder is not the successful Bidder, thirty days after the expiration of the Bidder's Tender validity period, being *[date of expiration of the Tender]*.

Consequently, we must receive at the above-mentioned office any demand for payment under this guarantee on or before that date.

Signature

Signature

Dated Sign.....Bidders Name.....

Section 5. General Conditions of Contract

1. Definitions
- 1.1 The following words and expressions shall have the meaning hereby assigned to them. Boldface type is used to identify the defined terms:
- (a) **Completion Certificate** means the Certificate issued by the Employer as evidence that the Contractor has executed the Works in all respects as per drawing, specifications, and Conditions of Contract.
 - (b) The **Completion Date** is the date of completion of the Works as certified by the Engineer, in accordance with GCC Clause 18.
 - (c) **Contract** means the Agreement entered into between the Employer and the Contractor to execute, complete and maintain the Works.
 - (d) **Contractor** means the person or corporate body whose Tender to carry out the Works has been accepted by the Employer and is named as such in the SCC.
 - (e) **Contract Price** is the price stated in the Letter of Acceptance and thereafter as adjusted in accordance with the provisions of the Contract. The **Contractor's Bid** is the completed Bid Document including the priced offer submitted by the Contractor to the Employer.
 - (f) **Days** mean calendar days.
 - (g) A **Defect** is any part of the Works not completed in accordance with the Contract.
 - (h) The **Employer** is the party named in the SCC who employs the Contractor to carry out the Works.
 - (i) The **Engineer** is the person named in the SCC, who is responsible for supervising the execution of the works and administering the Contract.
 - (j) The **Intended Completion Date** is the date specified in the SCC on which the Contractor shall complete the Works and may be revised if extension of time or an acceleration order is issued by the Engineer.
 - (k) The **Site** is the area defined as such in the SCC.
 - (l) The **Works** are what the Contract requires the Contractor to construct, install, and hand over to the Employer, as defined in the SCC.
2. Interpretation & Documents forming the Contract
- 2.1 In interpreting the GCC, singular also means plural, male also means female or neuter, and the other way around. Headings in the GCC shall not be deemed part thereof or be taken into consideration in the interpretation or construance of the Contract. Words have their normal meaning under the language of the

Contract unless specifically defined.

2.2 The following documents forming the Contract shall be interpreted in the following order of priority:

- (a) the signed Contract Agreement.
- (b) the letter of Notification of Award.
- (c) the completed Bid form as submitted by the Bidder.
- (d) the Special Conditions of Contract.
- (e) the General Conditions of Contract.
- (f) Specifications
- (g) the Drawings.
- (h) any other document listed in the PCC as forming part of the Contract.

3. Corrupt,
Fraudulent,
Collusive or
Coercive Practices

3.1 The Government requires that Employers, as well as Contractors shall observe the highest standard of ethics during the implementation of procurement proceedings and the execution of Contracts under public funds.

3.2 In pursuance of this requirement, the Employer shall

- (a) exclude the Contractor from participation in the procurement proceedings concerned or reject a proposal for award; and
- (b) declare a Contractor ineligible, either indefinitely or for a stated period of time, from participation in procurement proceedings under public fund;

3.3 The Government defines, for the purposes of this provision, the terms set forth below as follows:

- (a) corrupt practice⁵ is the offering, giving, receiving or soliciting, directly or indirectly, of anything of value⁶ to influence improperly the actions of another party;
- (b) "fraudulent practice"⁷ is any intentional act or omission, including a misrepresentation, that knowingly or recklessly misleads, or attempts to mislead, a party to obtain a financial or other benefit or to avoid an obligation;
- (c) "collusive practice"⁸ is an arrangement between

⁵ "another party" refers to a public official acting in relation to the procurement process or contract execution. In this context, "public official" includes staff and employees of any organizations (including any institutions providing finance for the Works) taking or reviewing procurement decisions.

⁶ "anything of value" includes, but is not limited to, any gift, loan, fee, commission, valuable security or other asset or interest in an asset; any office, employment or contract; any payment, discharge or liquidation of any loan, obligation or other liability whatsoever, whether in whole or in part; any other services, favour or advantage, including protection from any penalty or disability incurred or apprehended or from any action or proceeding of a disciplinary or penal nature, whether or not already instituted and including the exercise or the forbearance from the exercise of any right or any official power or duty.

⁷ a "party" refers to a public official; the terms "benefit" and "obligation" relate to the procurement process or contract execution; and the "act or omission" is intended to influence the procurement process or contract execution.

⁸ "parties" refers to participants in the procurement process (including public officials) and an "improper purpose" includes attempting to establish bid prices at artificial, non competitive levels.

two or more parties designed to achieve an improper purpose, including to influence improperly the actions of another party; and

(d) “coercive practice”⁹ is impairing or harming, or threatening to impair or harm, directly or indirectly, any party or the property of the party to influence improperly the actions of a party.

3.4 The Government requires that the Client’s personnel have an equal obligation not to solicit, ask for and/or use coercive methods to obtain personal benefits in connection with the said proceedings.

- | | |
|---|--|
| 4. Governing Language and Law | 4.1 The Contract as well as all correspondence and documents relating to the Contract exchanged by the Contractor and the Employer, shall be written in English unless otherwise stated in the SCC. The Contract shall be governed by and interpreted in accordance with the laws of the Kingdom of Bhutan. |
| 5. Engineer’s Decision | 5.1 Except where otherwise specifically stated in the SCC, the Engineer will decide Contractual matters between the Employer and the Contractor in the role as representative of the Employer. |
| 6. Delegation | 6.1 The Engineer may delegate any of his duties and responsibilities to his representative, after notifying the Contractor, and may cancel any delegation, without retroactivity, after notifying the Contractor. |
| 7. Communications and Notices | 7.1 Communications between Parties pursuant to the Contract shall be in writing to the address specified in the SCC. A notice shall be effective when delivered or on the notice’s effective date, whichever is later. |
| 8. Sub- Contracting | 8.1 The Contractor shall not be permitted to subcontract any part of the Works in whole or in part. |
| 9. Contractor’s Personnel | 9.1 The Contractor shall employ the key personnel named in the Schedule of Key Personnel, as referred to in the SCC, to carry out the functions stated in the Schedule, or other personnel approved by the Engineer. |
| 10. Welfare of Labourers & Child Labour | 10.1 The Contractor shall provide proper accommodation to his labourers and arrange proper water supply, conservancy and sanitation arrangements at the site in accordance with relevant regulations, rules and orders of the government.

10.2 The Contractor shall comply with the applicable minimum age, labour laws and requirements of (including applicable treaties which have been ratified by) the Government of Bhutan regarding hazardous forms of child labour. |

⁹ a “party” refers to a participant in the procurement process or contract execution.

- | | |
|--|---|
| 11. Safety, Security and Protection of the Environment | 11.1 The Contractor shall throughout the execution and completion of the Works and the remedying of any defects therein : <ul style="list-style-type: none"> (a) have full regard for the safety of all persons entitled to be upon the Site and keep the Site and the Works in an orderly state; (b) provide and maintain at the Contractors own cost all lights, guards, fencing, warning signs and watching for the protection of the Works or for the safety on-site; and (c) take all reasonable steps to protect the environment on and off the Site and to avoid damage or nuisance to persons or to property of the public or others resulting from pollution, noise or other causes arising as a consequence of the Contractors methods of operation. |
| 12. Access to the Site | 12.1 The Contractor shall allow the Engineer and any person authorised by the Engineer access to the Site and to any place where work in connection with the Contract is being carried out or is intended to be carried out. |
| 13. Documents, Information. | 13.1 The Contractor shall furnish to the Engineer all information, schedules, calculations and supporting documentation that may be requested of it. |
| 14. Property | 14.1 If the contract is terminated by the Employer because of the contractors default, then, the contractor shall not be allowed to remove any materials on the Site, Plant, and Temporary Works until the matter is amicably resolved. |
| 15. Insurance | 15.1 The Contractor shall provide insurance as stated in the SCC
15.2 The Contractor shall deliver policies and certificates of insurance to the Engineer, for the Engineer's approval, before the Start Date.
15.3 If the Contractor does not provide any of the policies and certificates required, the Employer may effect the insurance which the Contractor should have provided and recover the premiums the Employer has paid from payments otherwise due to the Contractor or, if no payment is due, the payment of the premiums shall be a debt due. |
| 16. Possession of the Site | 16.1 The Employer shall give possession of the Site, or parts of the Site, to the Contractor on the date(s) specified in the SCC. |
| 17. Commencement of Works | 17.1 The Contractor may commence execution of the Works on the Start Date, or other such date as specified in the SCC, and shall carry out the Works in an expeditious manner.
17.2 If the Contractor fails to commence the works within the above stated period, the Employer may, at his sole discretion, terminate the Contract and forfeit the Performance Security, if any. |
| 18. Completion of Works | 18.1 The Contractor shall complete the Works within the number of days stated in the SCC from the date of commencing the Works on the Site. |

19. Programme of Works	19.1	Within the time stated in the SCC, the Contractor shall submit to the Engineer for approval a work program. The Contractor shall submit to the Engineer for approval an updated Programme at intervals no longer than the period stated in the SCC.
20. Early Warning	20.1	The Contractor shall warn the Engineer at the earliest opportunity of specific likely future events or circumstances that may adversely affect the quality of the work result in increase to the Contract Price or delay in the execution of the Works.
21. Compensation Events	21.1	The following shall be Compensation Events: <ul style="list-style-type: none"> (a) the Employer does not give access to the Site or part of the Site by the Site Possession Date stated in the SCC; and (b) if the payment is delayed pursuant to Clause 25.1.
	21.2	If a Compensation Event would prevent the work being completed before the Intended Completion Date, the Intended Completion Date shall be extended, as appropriate, by the Engineer.
22. Non-Scheduled Items of Works	22.1	The Contractor shall be paid for non-scheduled items of works only when the Engineer approves such works and at the rates and in the manner stated in the SCC.
23. Schedule of Works	23.1	The Schedule of Works will contain rates for all items for the construction including temporary works, installation, testing, and commissioning work to be done by the Contractor.
	23.2	The Contractor shall be paid for the quantity of the work done at the rate in the Contract Agreement for each item.
	23.3	The Contractor shall be entirely responsible for all taxes, duties, license fees, and other such levies imposed outside and inside Bhutan.
24. Payment Certificates	24.1	The Contractor shall submit to the Engineer monthly statements of the estimated value of the work executed less the cumulative amount certified previously. The Engineer shall check the Contractor's monthly statement and certify the amount to be paid to the Contractor.
	24.2	The value of work executed shall be determined by the Engineer.
	24.3	The value of work executed shall comprise the value of the quantities of the items in the Schedule of Works completed.
	24.4	The value of work executed shall include the valuation of Variations, Certified Dayworks and Compensation Events.
	24.5	The Engineer may exclude any item certified in previous certificates or reduce the proportion of any item previously certified in any certificate in the light of later information.
25. Payments and Currency	25.1	The Employer shall pay the Contractor the amounts certified by the Engineer within thirty (30) days of the date of each certificate.
	25.2	The Employer shall make Advance Payment (mobilization and secured advance) to the Contractor of the amounts and by the dates stated in the SCC against provision by the Contractor of an unconditional Bank Guarantee, (Form 4).
	25.3	The Contractor is to use the advance payment only to pay for Equipment, Plant, Materials, and mobilisation expenses required

specifically for the execution of the Contract. The Contractor shall demonstrate that the advance payment has been used in this way by submitting copies of invoices or other documents to the Employer.

- 25.4 The advance payment shall be repaid by deducting proportionate amounts from payments otherwise due to the Contractor, following the schedule of completed percentages of the Works on a payment basis. No account shall be taken of the advance payment or its repayment in assessing valuations of work done, variations, claims or any amount payable due to failure to complete the works.
- 26. Retention
 - 26.1 The Employer shall retain from each payment due to the Contractor the proportion stated in the SCC until the completion of the whole of the Works.
 - 26.2 On completion of the whole of the Works, half the total amount retained shall be repaid to the Contractor, the remaining half when the Defects Liability Period has passed and the Engineer has certified that all Defects notified by the Engineer to the Contractor before the end of this period have been corrected.
- 27. Liquidated Damages
 - 27.1 The Contractor shall pay liquidated damages to the Employer at the rate per day stated in the SCC for each day that the Completion Date is later than the Intended Completion date for the works or for any part thereof.
- 28. Performance Security
 - 28.1 Upon Notification of Award, a Performance Security shall be provided to the Employer in the amount and form stated in the Contract Forms (Form 3). The Performance Security shall be valid until a date thirty (30) days from the date of issue of the Certificate of Completion.
- 29. Price Adjustment
 - 29.1 The rates and prices in the bill of quantities are fixed for the duration of the Contract and not subject to price adjustment during the performance of the Contract.
- 30. Completion
 - 30.1 The Contractor shall request the Engineer to issue a Certificate of Completion of the Works, and the Engineer will do so upon deciding that the work is substantially completed.
- 31. Correction of Defects
 - 31.1 The Engineer shall give notice to the Contractor of any Defects before the end of the Defects Liability Period, which begins at Completion, and is defined in the SCC. The Defects Liability Period shall be extended for as long as the Defects remain to be corrected.
 - 31.2 If the Contractor has not corrected a Defect within the time specified in the Engineer's notice, the Engineer will assess the cost of having the Defect corrected, and the Contractor will pay this amount.
- 32. Taking Over
 - 32.1 The Employer shall take over the Site and the Works within seven (7) days of the Engineer issuing a Certificate of Completion.

33. Final Account
- 33.1 The Contractor shall supply the Engineer a detailed account of the total amount that the Contractor considers payable under the Contract. The Engineer shall certify any final payment that is due to the Contractor within twenty-one (21) days of receiving the Contractor's account if it is correct and complete.
- 33.2 The Employer shall effect payment of the final account within thirty (30) days from the date of certification by the Engineer.
34. Termination
- 34.1 The Employer or the Contractor by giving thirty (30) days written notice of default to the other party, may terminate the Contract in whole or in part if the other party causes a fundamental breach of Contract.
- 34.2 Fundamental breaches of the Contract shall include, but shall not be limited to, the following:
- (a) the Contractor stops work for more than thirty (30) days when no stoppage of work is shown on the current Programme and the stoppage has not been authorised by the Engineer;
 - (b) the Engineer gives notice that failure to correct a particular defect is a fundamental breach of Contract and the Contractor fails to correct it within a reasonable period of time determined by the Engineer;
 - (c) the Contractor has delayed the completion of the Works by the number of days for which the maximum amount of Liquidated Damages can be paid;
 - (d) the Contractor, in the judgment of the Employer, has engaged in corrupt or fraudulent practices, as defined in GCC Clause 3, in competing for or in executing the Contract; and
 - (e) a payment certified by the Engineer is not paid to the Contractor by the Employer within sixty (60) days of the date of the Engineer's certificate.
- 34.3 The Employer and the Contractor may at any time terminate the Contract by giving notice to the other party if either of the parties becomes bankrupt or otherwise insolvent. In such event, termination will be without compensation to any party provided that such termination will not prejudice or affect any right of action or remedy that has accrued or will accrue to the other party.
- 34.4 Notwithstanding the above, the Employer may terminate the Contract for convenience.
- 34.5 If the Contract is terminated, the Contractor is to stop work immediately, make the Site safe and secure and hand over the Site to the Employer as soon as reasonably possible.

35. Payment upon Termination
- 35.1 If the Contract is terminated because of a fundamental breach of Contract by the Contractor, the Engineer shall issue a certificate for the value of the work done and Plant and Materials ordered less advance payments received up to the date of the issue of the certificate and less the percentage to apply to the value of the work not completed, as indicated in the SCC.. Additional Liquidated Damages shall not apply. If the total amount due to the Employer exceeds any payment due to the Contractor, the difference shall be a debt payable to the Employer.
- 35.2 If the Contract is terminated for the Employer's convenience or because of a fundamental breach of Contract by the Employer, the Contractor shall be entitled to payments for completed works and the materials that have been brought to the site for the purpose of the works, but not used as certified by the Engineer after adjusting any payments received by the Contractor.
36. Release from Performance
- 36.1 If the Contract is frustrated by the outbreak of war or by any other event entirely outside the control of either the Employer or the Contractor, the Engineer shall certify that the Contract has been frustrated. The Contractor shall make the Site safe and stop work as quickly as possible, after receiving this certificate. The Contractor shall be paid for all works carried out before stoppage of work and any work carried out afterwards to which a commitment was made.
37. Force Majeure
- 37.1 For the purposes of this Contract, "Force Majeure" means an exceptional event or circumstance:
- (a) which is beyond a Party's control,
 - (b) which such Party could not reasonably have provided against before entering into the Contract,
 - (c) which, having arisen, such Party could not reasonably have avoided or overcome, and
 - (d) which is not substantially attributable to the other Party.
- 37.2 Force Majeure may include, but is not limited to, exceptional events or circumstances of the kind listed below, so long as conditions (a) to (d) above are satisfied:
- (a) war, hostilities (whether war be declared or not), invasion, act of foreign enemies,
 - (b) rebellion, terrorism, sabotage by persons other than the Contractor's Personnel, revolution, insurrection, military or usurped power, or civil war,
 - (c) riot, commotion, disorder, strike or lockout by persons other than the Contractor's Personnel,
 - (d) munitions of war, explosive materials, ionizing radiation or contamination by radio-activity, except as may be attributable to the Contractor's use of such munitions, explosives, radiation or radio-activity, and
 - (e) natural catastrophes such as earthquake, hurricane, typhoon or volcanic activity.
- 37.3 However, force majeure shall not include the following;
- i. rainfall
 - ii. snowfall

iii. strikes in other countries

iv. non-availability of labourer and materials such as timbers, boulders, sand, and other materials

v. difficulty and risky terrain and remoteness of site.

38. Settlement of Disputes

38.1 The Employer and the Contractor shall use their best efforts to settle amicably all disputes arising out of or in connection with this Contract or its interpretation.

38.2 Any dispute between the parties to the Contract that may not be settled amicably will be referred to Arbitration at the initiative of either of the parties.

38.3 The Arbitration shall be conducted in accordance with the Arbitration Rules of the Kingdom of Bhutan in force.

INTEGRITY PACT

1 General:

Whereas (*Lhaten Dorji*) representing the (*Pemagatshel Dzong Construction Project*), Royal Government of Bhutan, hereinafter referred to as the “**Employer**” on one part, and
(.....*Name of bidder*)
representing
M/s. (.....*Name of firm*),
hereinafter referred to as the “**Bidder**” on the other part hereby execute this agreement as follows:

This agreement shall be a part of the standard bidding document, which shall be signed by both the parties at the time of purchase of bidding documents and submitted along with the tender document. This IP is applicable only to “**Medium**” scale works, goods and services, the threshold of which will be announced by the government from time to time. The signing of the IP shall not apply to framework contracting such as annual office supplies etc.

2 Objectives:

Whereas, the Employer and the Bidder agree to enter into this agreement, hereinafter referred to as IP, to avoid all forms of corruption or deceptive practice by following a system that is fair, transparent and free from any influence/unprejudiced dealings in the **bidding process** and **contract administration**, with a view to:

- 2.1 Enabling the Employer to obtain the desired contract at a reasonable and competitive price in conformity to the defined specifications of the works or goods or services; and
- 2.2 Enabling bidders to abstain from bribing or any corrupt practice in order to secure the contract by providing assurance to them that their competitors will also refrain from bribing and other corrupt practices.

3. Scope:

The validity of this IP shall cover the bidding process and contract administration period.

4. Commitments of the Employer:

The Employer Commits itself to the following:-

- 4.1 The Employer hereby undertakes that no officials of the Employer, connected directly or indirectly with the contract, will demand, take a promise for or accept, directly or through intermediaries, any bribe, consideration, gift, reward, favor or any material or immaterial benefit or any other advantage from the Bidder, either for themselves or for any person, organization or third party related to the contract in exchange for an advantage in the bidding process and contract administration.
- 4.2 The Employer further confirms that its officials shall not favor any prospective bidder in any form that could afford an undue advantage to that particular bidder in the bidding process and contract administration and will treat all Bidders alike.
- 4.3 Officials of the Employer, who may have observed or noticed or have reasonable suspicion shall report to the head of the employing agency or an appropriate

Dated Sign.....Bidders Name.....

government office any violation or attempted violation of clauses 4.1 and 4.2.

4.4 Following report on violation of clauses 4.1 and 4.2 by official (s), through any source, necessary disciplinary proceedings, or any other action as deemed fit, including criminal proceedings shall be initiated by the Employer and such a person shall be debarred from further dealings related to the bidding process and contract administration.

5. Commitments of Bidders

The Bidder commits himself/herself to take all measures necessary to prevent corrupt practices, unfair means and illegal activities during any stage of the bidding process and contract administration in order to secure the contract or in furtherance to secure it and in particular commits himself/herself to the following :-

5.1 The Bidder shall not offer, directly or through intermediaries, any bribe, gift, consideration, reward, favor, any material or immaterial benefit or other advantage, commission, fees, brokerage or inducement to any official of the Employer, connected directly or indirectly with the bidding process and contract administration, or to any person, organization or third party related to the contract in exchange for any advantage in the bidding process and contract administration.

5.2 The Bidder shall not collude with other parties interested in the contract to manipulate in whatsoever form or manner, the bidding process and contract administration.

5.3 If the bidder(s) have observed or noticed or have reasonable suspicion that the provisions of the IP have been violated by the procuring agency or other bidders, the bidder shall report such violations to the head of the procuring agency.

6. Sanctions for Violation:

The breach of any of the aforesaid provisions shall result in administrative charges or penal actions as per the relevant rules and laws.

6.1 The breach of the IP or commission of any offence (forgery, providing false information, mis-representation, providing false/fake documents, bid rigging, bid steering or coercion) by the Bidder, or any one employed by him, or acting on his/her behalf (whether with or without the knowledge of the Bidder), shall be dealt with as per the terms and conditions of the contract and other provisions of the relevant laws, including De-barment Rules.

6.2 The breach of the IP or commission of any offence by the officials of the procuring agency shall be dealt with as per the rules and laws of the land in vogue

7. Monitoring and Administration:

7.1 The respective procuring agency shall be responsible for administration and monitoring of the IP as per the relevant laws.

7.2 The bidder shall have the right to appeal as per the arbitration mechanism contained

Dated Sign.....Bidders Name.....

in the relevant rules.

We, hereby declare that we have read and understood the clauses of this agreement and shall abide by it.

The parties hereby sign this Integrity Pact at (place) _____ on (date) _____



EMPLOYER

CID :

1	1	3	1	2	0	0	2	4	8	1
---	---	---	---	---	---	---	---	---	---	---

Witness

Name: Damcho Penjor

CID;

1	1	5	1	2	0	0	3	8	8	9
---	---	---	---	---	---	---	---	---	---	---

Affix
Legal
Stamp

BIDDER/REPRESENTATIVE

CID;

--	--	--	--	--	--	--	--	--	--	--

Witness

Name:

CID;

--	--	--	--	--	--	--	--	--	--	--

Section 6. Special Conditions of Contract

Instructions for completing the Special Conditions of Contract are provided, as needed, in the notes in italics mentioned for the relevant GCC Clauses.3

Clause Ref	Amendments of, and Supplements to, Clauses in the General Conditions of Contract
GCC 1.1(d)	The Contractor is;
GCC 1.1(i)	The Employer is ; Pemagatshel Dzong Construction Project
GCC 1.1(j)	The Engineer is; Damcho Penjor
GCC 1.1(k)	The Intended Completion Date for the whole of the Works shall be [30th June 2019] .
GCC 1.1(l)	The Site is located at; Denchhi, Pemagatshel.
GCC 1.1(m)	<p>The Works are; <i>Supply of materials for aluminium partition with accessories including 6mm double glazing clear glass with ozone fittings, door frame and shutter with hafele fittings complete to project site. Installation of Aluminum partition as per the drawings provided and in close consultation with Project Engineer.</i></p> <p>***The designated area for the installation for aluminium partition is at Ground Floor, first floor and second floor of Administrative Blocks C & E.</p>
GCC 2.2(i)	<p>The additional documents forming part of this Contract are:</p> <p><i>"No additional documents".</i></p>
GCC 4.1	The Language governing the Contract shall be; English
GCC 5.1	The Contractor shall obtain specific approval of the Employer before commencing any work.
GCC 7.1	<p>The addresses for Communications shall be:</p> <p><u>For the Employer:</u> Lhaten Dorji, Project Manager, PDCP</p> <p><u>For the Contractor:</u></p>
GCC 9.1	The Key Personnel of the Contractor are: Site Engineer or site supervisor
GCC 15.1	For insurance purposes the type of cover required shall be: The contractor shall be responsible for the insurance
GCC 16.1	Possession of the site shall be within [10] days from the date of signing of the Contract.
GCC 17.1	Commencement of work shall be within [10] days from the date of handing over possession of the Site.

GCC 18.1	Completion of works shall be given in the work order issued from the Project office
GCC 19.1 & 19.2	The Contractor shall submit the first workplan [15] days after signing the Contract, and shall update the workplan every [...1.....] weeks during the period of the Contract.
GCC 22.1	The rates for non-scheduled items of works shall be determined by the Engineer].
GCC 25.2	An advance payment of [10] % of the Contract Price will be made to the Contractor within (14) days of Contract signing date. [an advance payment is usually 10% of the contract price]
GCC 26.1	The Retention shall be [10] % of the Contract Price.
GCC 27.1	The liquidated damages for the whole of the Works are [0.10%] per day. The maximum amount of liquidated damages for the whole of the Works is [10] percent of the initial Contract Price.
GCC 31.1	The Defects Liability Period shall be [2 years]
GCC 35.1	The percentage to apply to the value of the work not completed, representing the Employer's additional cost for completing the Works, is 10% of initial contract price

Section 7 – Contract Forms

This section contains forms which, once completed, will form part of the Contract. The forms for Performance Security and Advance Payment Security, when required, shall only be completed by the successful Bidder after Contract award.

Contract Forms Form	Title
Form -1	Notification of Award
Form -2	Contract Agreement
Form -3	Bank Guarantee for Performance Security
Form -4	Bank Guarantee for Advance Payment

Notification of Award

Contract No:

Date:

To:

[name and address of Contractor]

This is to notify you that your Bid dated *[insert date]* for the execution of the Works for *[name of project / Contract]* for the Contract Price of Nu *[amount in figures and in words]*, as corrected and modified in accordance with the Instructions to bidder is hereby accepted by *[name of the Employer]*.

You are requested to proceed with the execution of the Works on the basis that this Notification of Award shall constitute the formation of a Contract, which shall become binding upon you furnishing a Performance Security within fourteen (14) days, in accordance with ITB Clause 32, and the signing the Contract Agreement within twenty-one (21) days, in accordance with ITB Clause 33.

We attach the Contract Agreement and Special Conditions of Contract for your perusal and signature.

Signed

Duly authorised to sign for and on behalf of
[name of Procuring Entity]

Date:

Contract Agreement

THIS AGREEMENT, made the [day] of [month] [year] between [name and address of Employer] (hereinafter called "the Employer") of the one part and [name and address of Contractor] (hereinafter called "the Contractor") of the other part.

WHEREAS, the Employer invited Tenders for certain Works, viz, [brief description of the Works] and has accepted a Tender by the Contractor for the execution of those works in the sum of Ngultrum [insert amount in figures and words], hereinafter called "the Contract Price.

NOW THIS AGREEMENT WITNESSETH as follows:

1. In this Agreement, words and expressions shall have the same meanings as are respectively assigned to them in the General Conditions of Contract hereinafter referred to.
2. The documents forming the Contract shall be interpreted in the following order of priority:
 - (a) The signed Contract Agreement;
 - (b) The letter of Acceptance;
 - (c) The completed Bid form as submitted by the Bidder;
 - (d) The Special Conditions of Contract;
 - (e) The General Conditions of Contract;
 - (f) Specifications
 - (g) The Drawings; and
 - (h) Any other document listed in the SCC as forming part of the Contract..
3. In consideration of the payments to be made by the Employer to the Contractor as hereinafter mentioned, the Contractor hereby covenants with the Employer to execute and complete the Works and to remedy any defects therein in conformity in all respects with the provisions of the Contract.
4. The Employer hereby covenants to pay the Contractor in consideration of the execution and completion of the Works and the remedying of defects therein, the Contract Price or such other sum as may become payable under the provisions of the Contract at the times and in the manner prescribed by the Contract.

IN WITNESS whereof the Parties thereto have caused this Agreement to be executed in accordance with the laws of Bhutan on the day month and year first before written.

For the Employer

For the Contractor

Signature

Print Name

Title

In the presence of
(Name)

Address

Bank Guarantee for Performance Security

[this is the format for the Performance Security to be issued by any financial institute in Bhutan in accordance with ITB Clause 35]

Contract No:

Date:

To:

[Name and address of Employer]

PERFORMANCE GUARANTEE No:

We have been informed that *[name of Contractor]* (hereinafter called "the Contractor") has undertaken, pursuant to Contract No *[reference number of Contract]* dated *[date of Contract]* (hereinafter called "the Contract"), the execution of works *[description of works]* under the Contract.

Furthermore, we understand that, according to your conditions, Contracts must be supported by a performance guarantee.

At the request of the Contractor, we *[name of bank]* hereby irrevocably undertake to pay you, without cavil or argument, any sum or sums not exceeding in total an amount of Nu *[insert amount in figures and in words]* upon receipt by us of your first written demand accompanied by a written statement that the Contractor is in breach of its obligation(s) under the Contract conditions, without you needing to prove or show grounds or reasons for your demand of the sum specified therein.

This guarantee is valid until *[date of validity of guarantee]*, consequently, we must receive at the above-mentioned office any demand for payment under this guarantee on or before that date.

Signature

Signature

Bank Guarantee for mobilisation advance

[this is the format for the Advance Payment Guarantee to be issued by a financial institutions in Bhutan in their letter pad in accordance with SCC Clause 25.2]

Contract No:

Date:

To:

[Name and address of Employer]

ADVANCE PAYMENT GUARANTEE No:

We have been informed that *[name of Contractor]* (hereinafter called "the Contractor") has undertaken, pursuant to Contract No *[reference number of Contract]* dated *[date of Contract]* (hereinafter called "the Contract"), the execution of works *[description of works]* under the Contract.

Furthermore, we understand that, according to your conditions, Advance Payments must be supported by a bank guarantee.

At the request of the Contractor, we *[name of bank]* hereby irrevocably undertake to pay you, without cavil or argument, any sum or sums not exceeding in total an amount of Nu. *[insert amount in figures and in words]* upon receipt by us of your first written demand accompanied by a written statement that the Contractor is in breach of its obligation(s) under the Contract conditions, without you needing to prove or show grounds or reasons for your demand of the sum specified therein.

We further agree that no change, addition or other modification of the terms of the Contract to be performed, or of any of the Contract documents which may be made between the Employer and the Contractor, shall in any way release us from any liability under this guarantee, and we hereby waive notice of any such change, addition or modification.

This guarantee is valid until *[date of validity of guarantee]*, consequently, we must receive at the above-mentioned office any demand for payment under this guarantee on or before that date.

Signature

Signature

Addendum to special condition of contract

- The period for the execution of the work is valid till 30th June 2019
- The copy of valid CDB license should be attached with the bid.

- The quoted rate shall remain same till the completion of contract period. Before quoting the rate, the bidders should study the nature of work and the site conditions. All interested bidders can approach the office of Dzong Construction Project for familiarization of the project.
- The progress and capability of the contractor will be strictly monitored by the PDCP management and the poor performance will result in termination of contract.
- The successful bidder will always work in close coordination with the PDCP management team.
- The decision of Dzong Construction Project committee is final and binding.

Bill of Quantities

Name of Work: **Supply and Installation of Aluminum Partition Works at Pemagatshel Dzong Construction Project**

Sl No.	Item Code	Description/ particulars	Qty.	Unit	Rate Nu.	Amount Nu.	Remarks
1	AL2.01.01	Providing and Fixing Aluminum frame and shutter including 6mm double glazing clear glass with ozone fittings, 10 mm laminated Particle board on both sides complete as per drawing	1002.29	sq.m			
2	D5	Providing and Fixing Aluminum frame and shutter - Door type D5 including 6mm tempered glass with Hafele fittings, 10 mm laminated particle board on both sides, 1.5 mm thick aluminum louver and accessories as per drawing.	46	nos			
Grand Total in Nu=							
Amounts in words:							

4. Technical Specification

Thickness of aluminum sections is 1.5 mm of superior quality. The color of the aluminum sections is black.

Please refer the attached drawing for the clear perspective of the intended work.

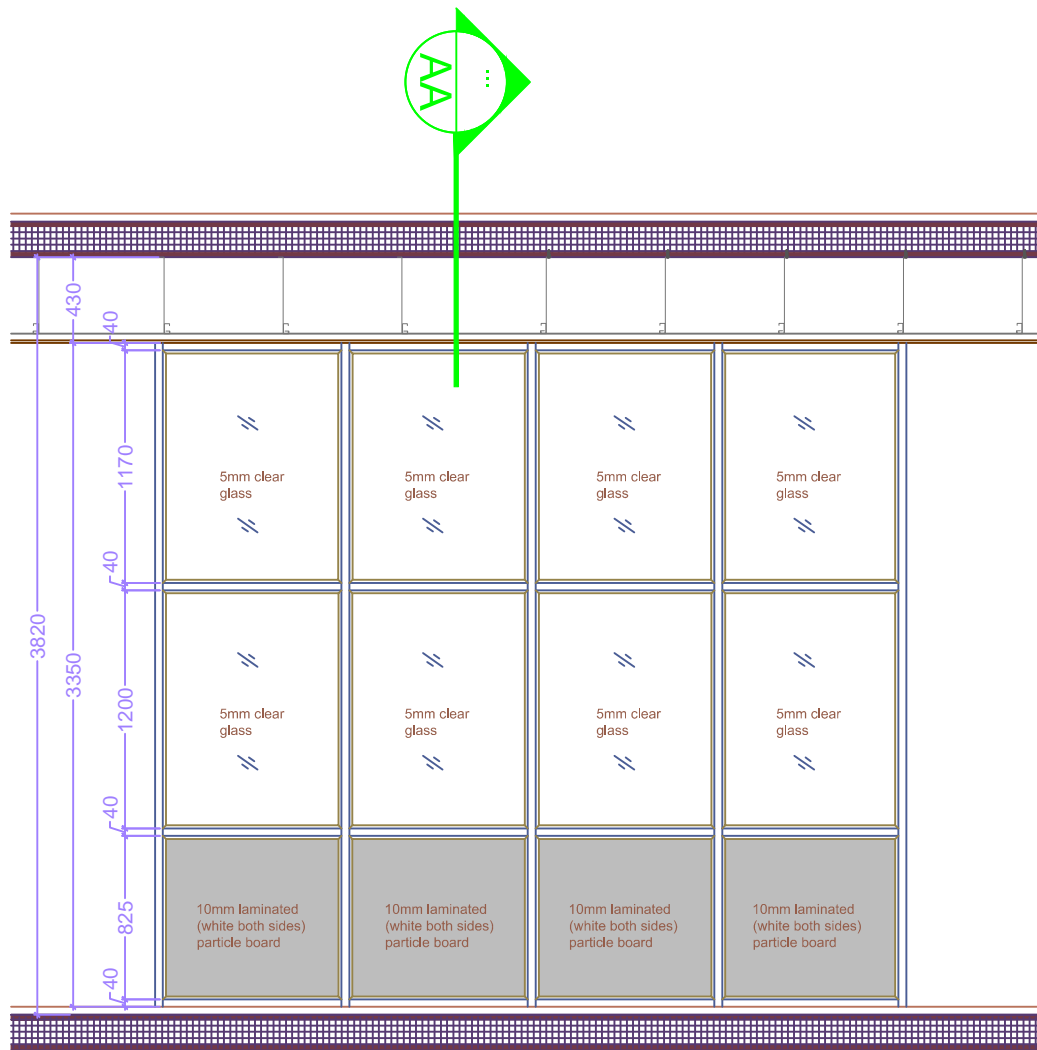

SECTIONAL ELEVATION

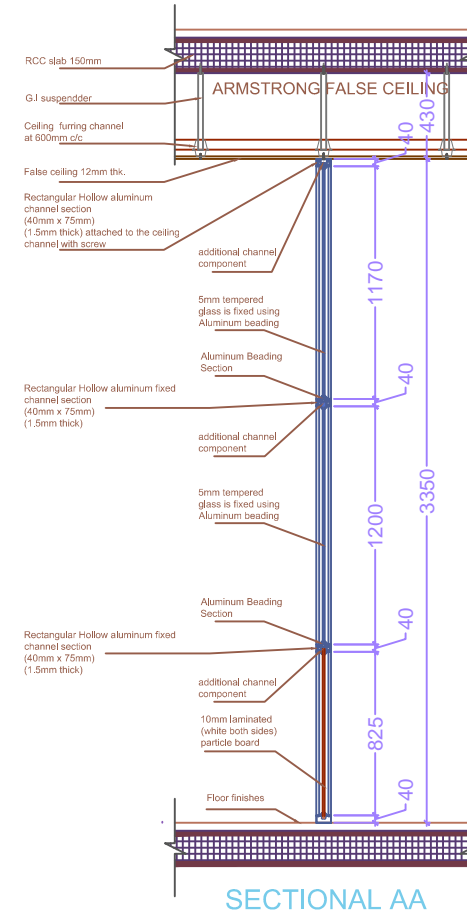

AL2

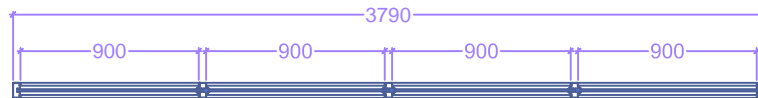

SECTIONAL PLAN

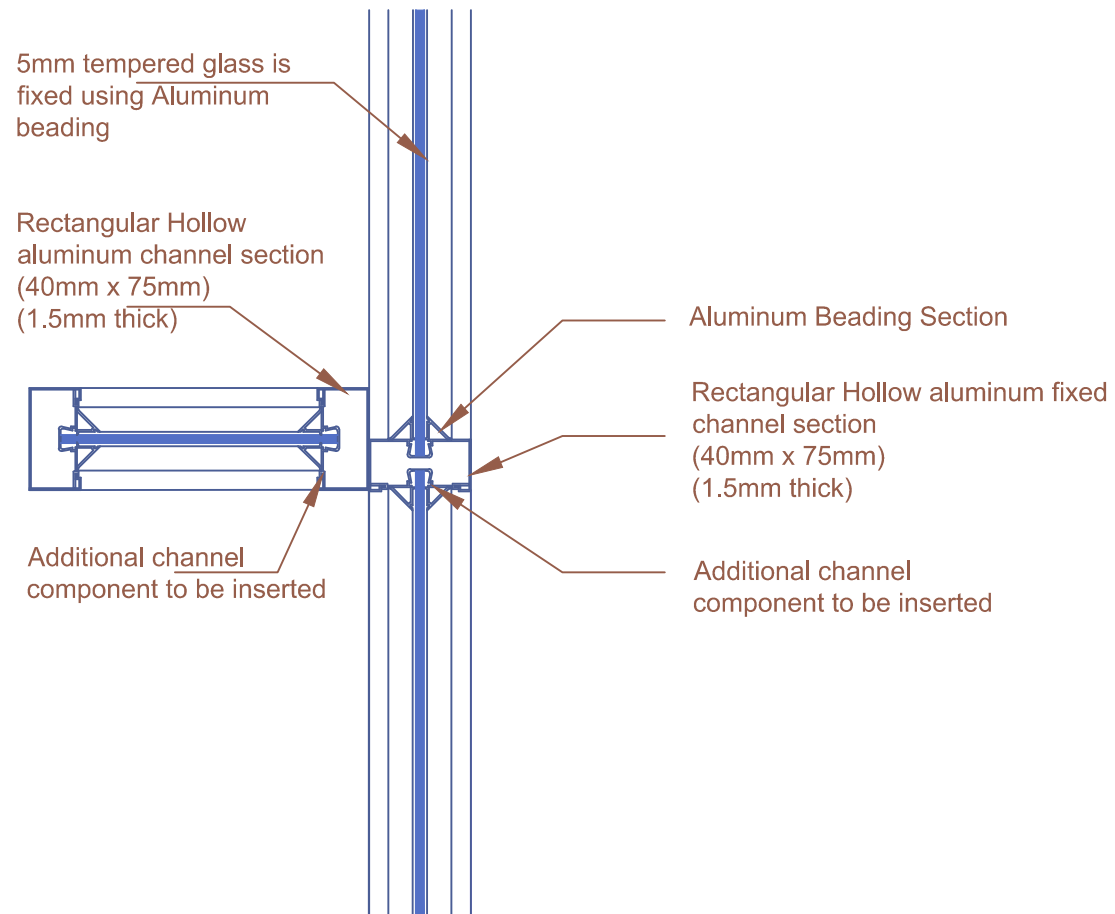

T-JUNCTION DETAILS OPTION 2

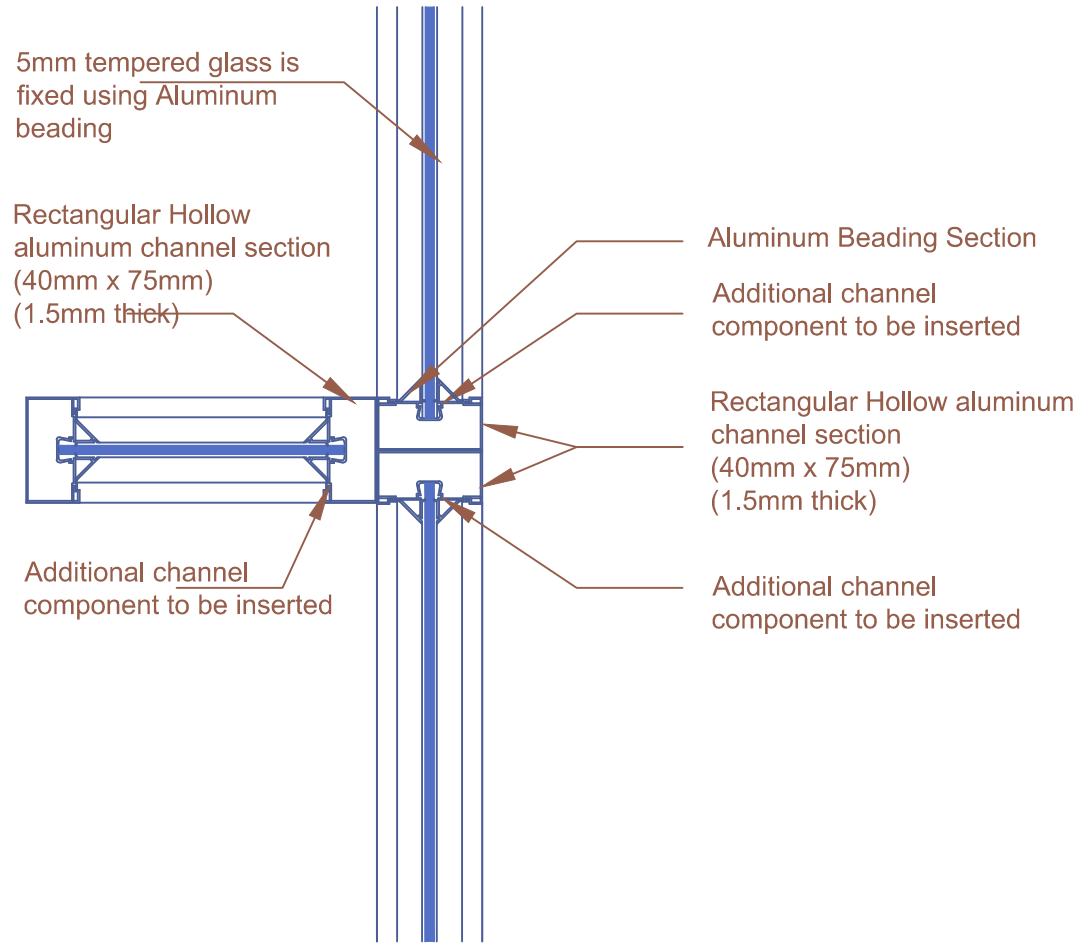

T-JUNCTION DETAILS OPTION 1

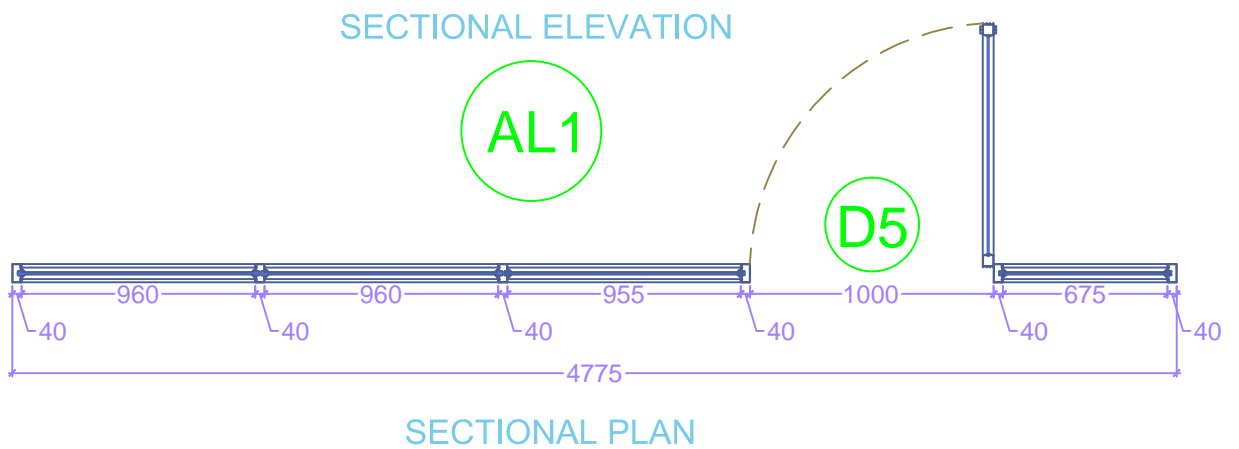
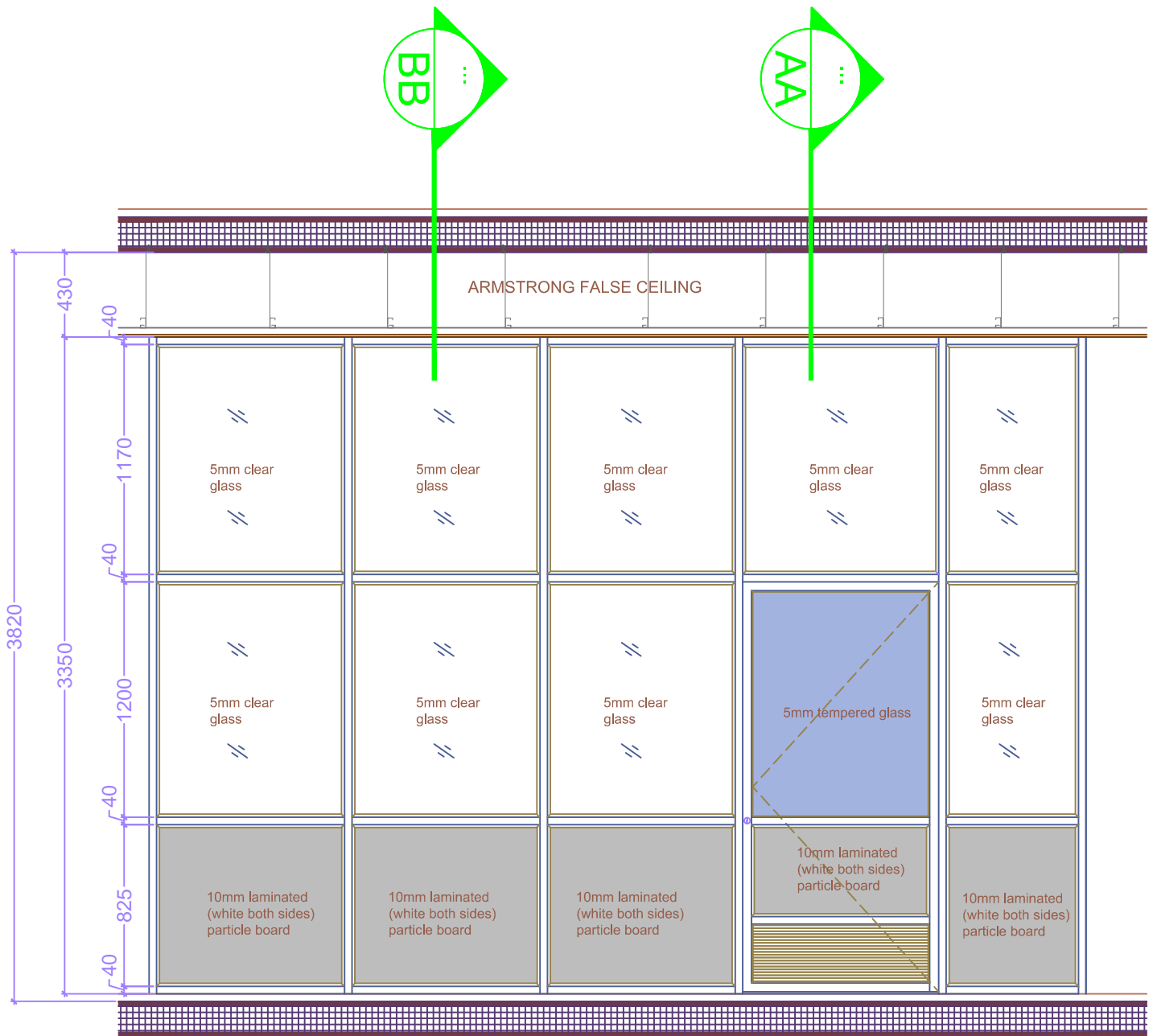

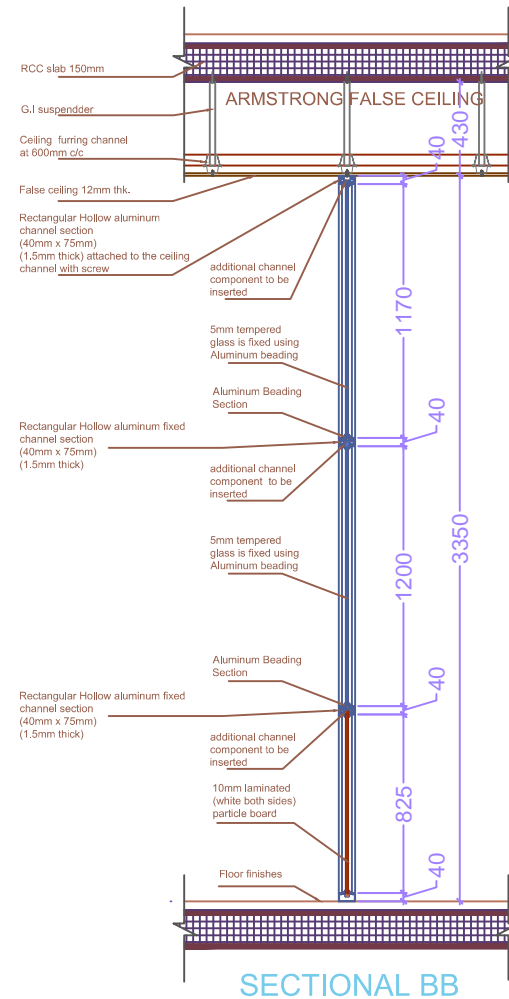
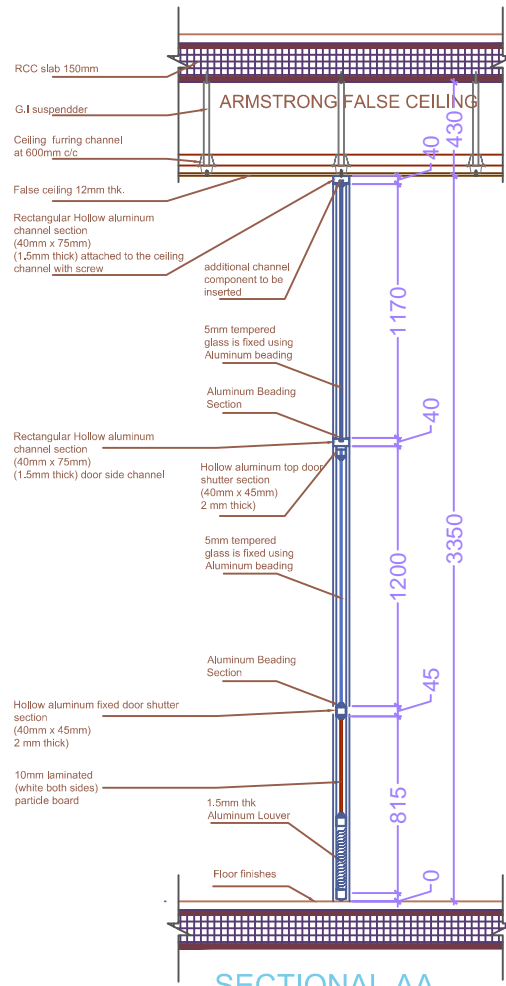

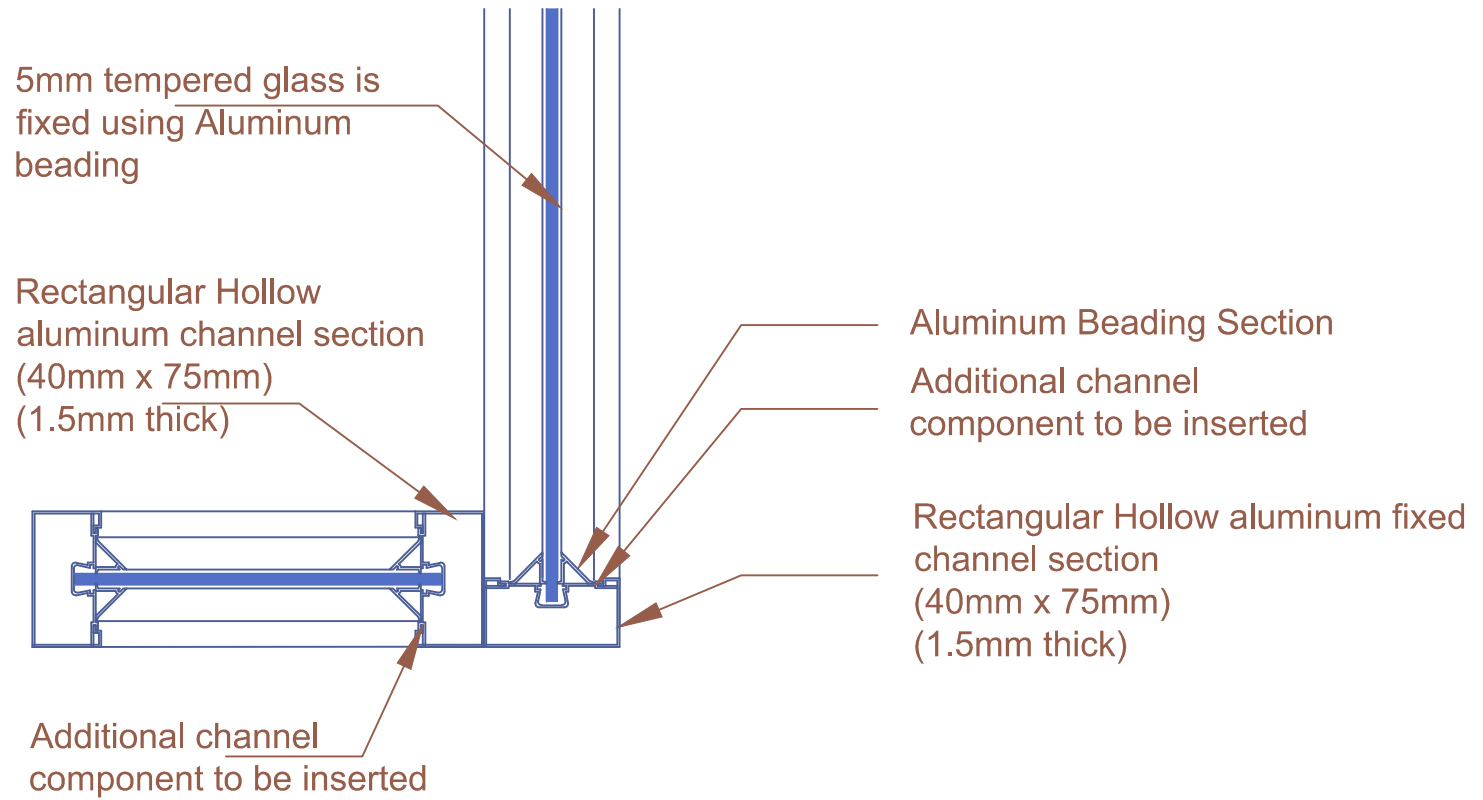

L-JUNCTION DETAILS

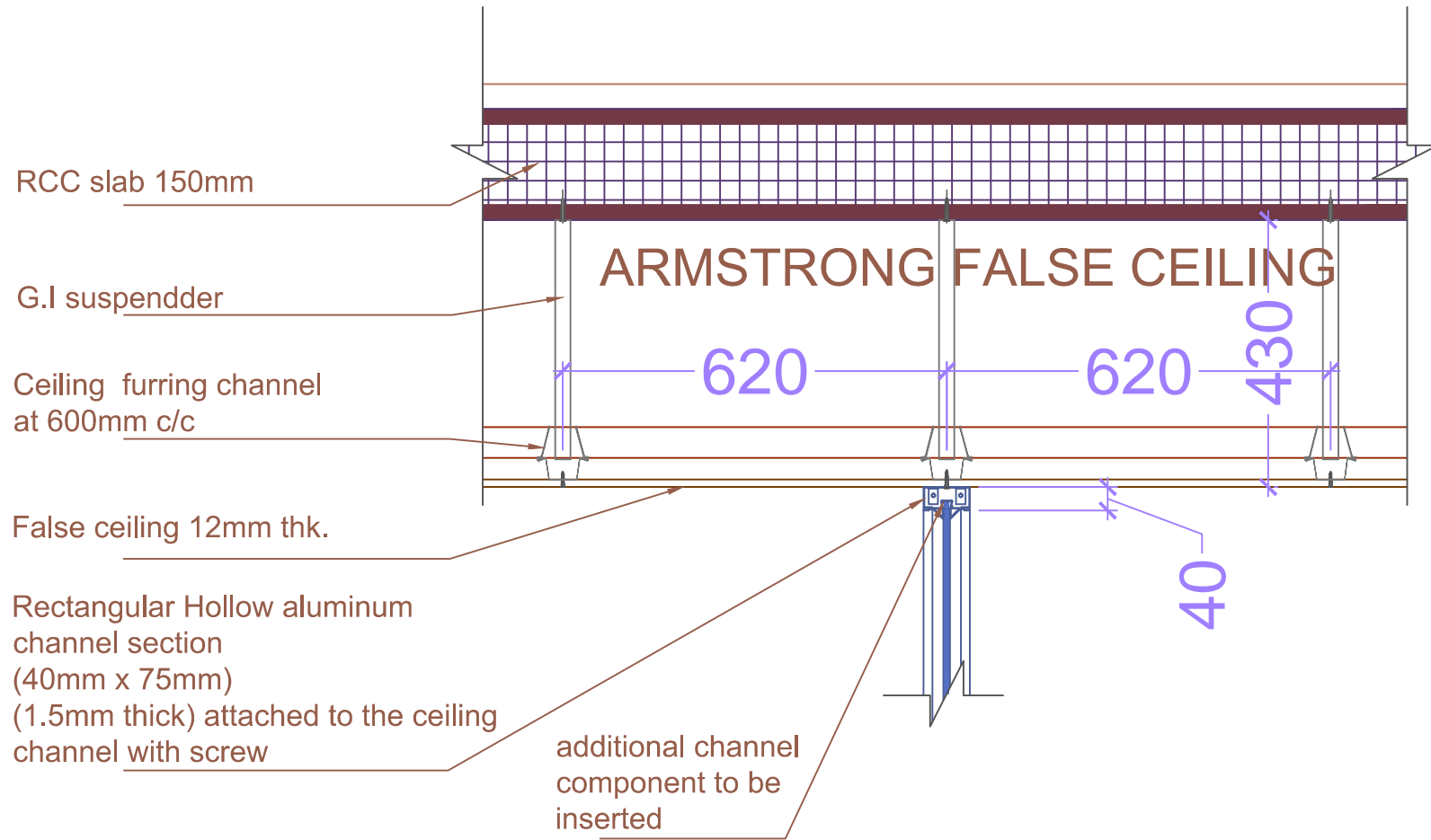

ARMSTRONG FALSE CEILING
TYPICAL SECTION

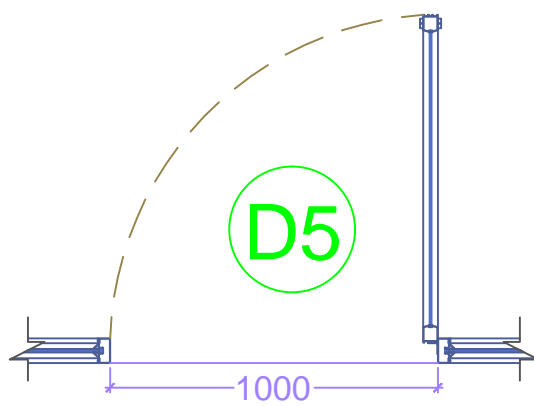
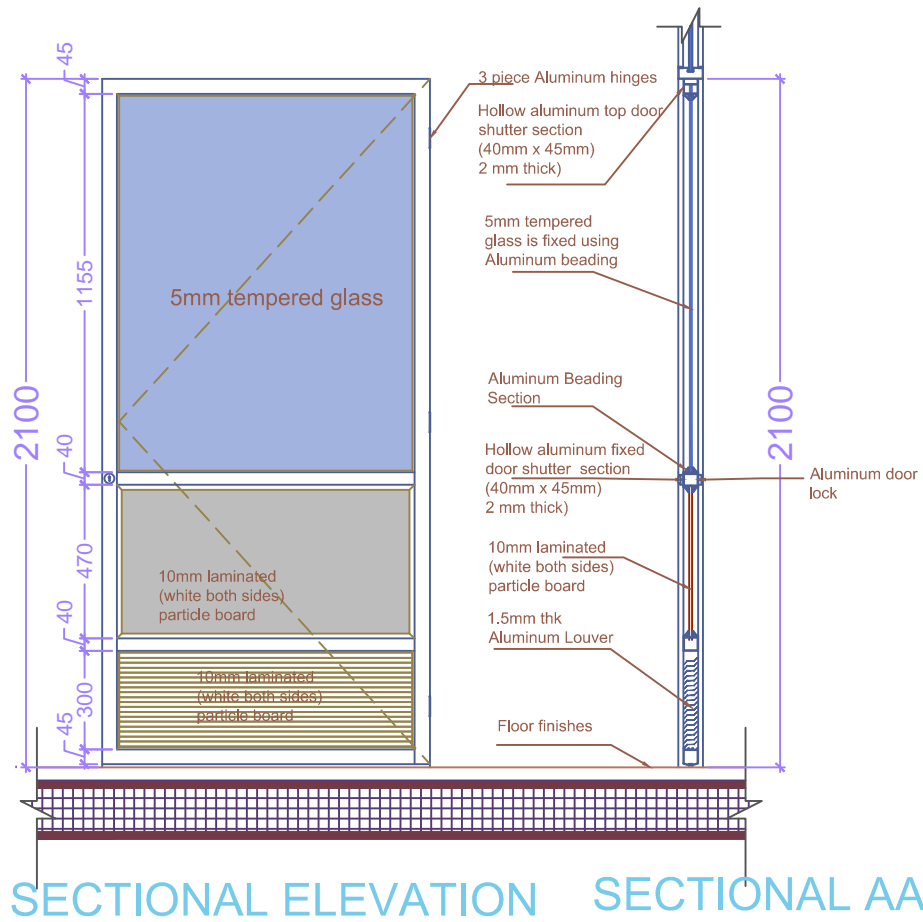

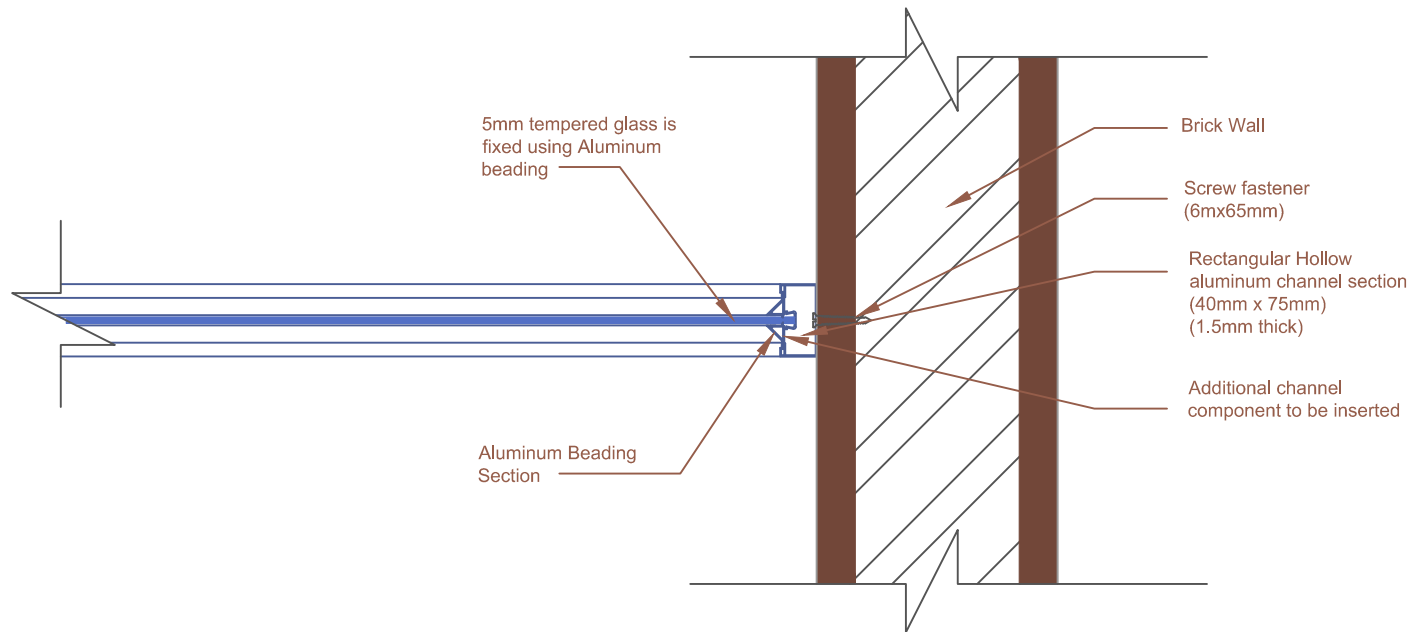

Aluminum Wall ending against the Brick Walls